

PEDESTAL MOD. A (3 Drawers)

190 001 00	4 wheels d40 no brake	with stationery tray
190 002 00	4 wheels d40 no brake	without stationery tray
190 081 00	2 wheels d45 with brake 2 wheels d45 no brake	with stationery tray
190 003 00	2 wheels d45 with brake 2 wheels d45 no brake	without stationery tray

FEATURES

- Drawers | Internal dimensions L352XP470XH88
Loading capacity of the drawer 15 kg
Partial extraction roller slides 4/5
- Anti-overturning system
- Lock with jointed double key

PACKAGING

- Gross weight 20 kg
- Volume 0.149 mc
- Packaging in double layer box with handle and 8 paper angular supports
- Pallet 16pz 100x120 h230

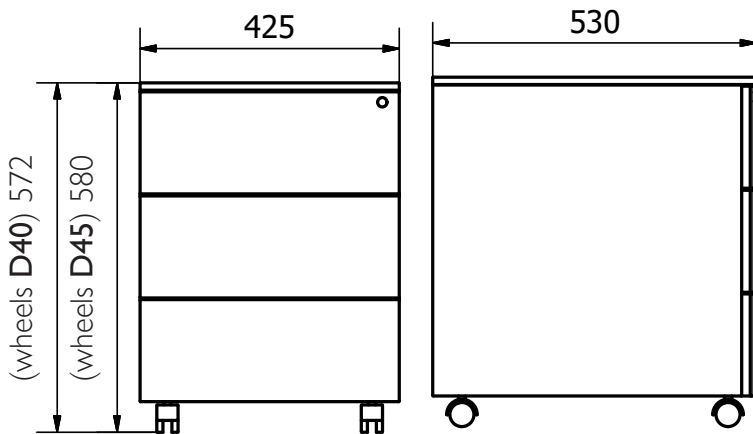
PEDESTAL MOD. C (1 Drawers / 1 Filing Cabinet)

190 067 00	5 wheels d40 no brake	with stationery tray
190 069 00	5 wheels d40 no brake	without stationery tray
190 083 00	2 wheels d45 with brake 3 wheels d45 no brake	with stationery tray
157 991 00	2 wheels d45 with brake 3 wheels d45 no brake	without stationery tray

FEATURES

- Drawers | Internal dimensions L352XP470XH88
Loading capacity of the drawer 15kg
Partial extraction roller slides 4/5
- Filing Cabinet | Internal dimensions L330XP452XH270
Loading capacity of the drawer 45kg
Full extension sliding guides
Folder-support framework
- Anti-overturning system
- Lock with jointed double key

PACKAGING

- Gross weight 20 kg
- Volume 0.149 mc
- Packaging in double layer box with handle and 8 paper angular supports
- Pallet 16pz 100x120 h230

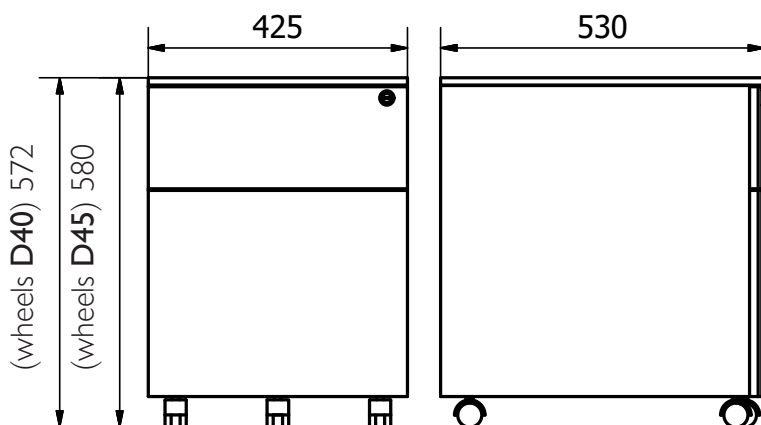

PEDESTAL MOD. E (3 Drawers / 1 Stationery Drawer)

190 006 00	4 wheels d40 no brake	with stationery tray
190 235 00	2 wheels d45 with brake 2 wheels d45 no brake	with stationery tray

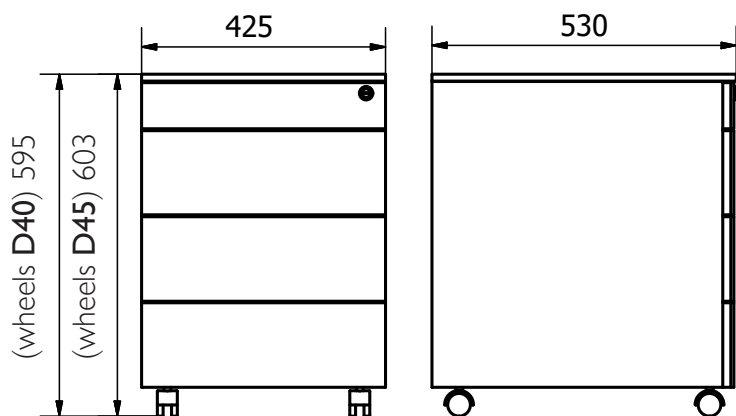
FEATURES

- Stationery tray | Internal dim. L352XP470XH25
Loading capacity 5kg
Partial extraction roller slides 4/5
- Drawers | Internal dim. L352XP470XH88
Loading capacity 15kg
Partial extraction roller slides 4/5
- Anti-overturning system
- Lock with jointed double key

PACKAGING

- Gross weight 22,3 kg
- Volume 0.149 mc
- Packaging in double layer box with handle and 8 paper angular supports
- Pallet 12pz 100x120 h190

PEDESTAL MOD. F (1 Drawer / 1 Filing Drawer / 1 Stationery Drawer)

158 108 00	2 wheels d45 with brake 3 wheels d45 no brake	with stationery tray
------------	--	----------------------

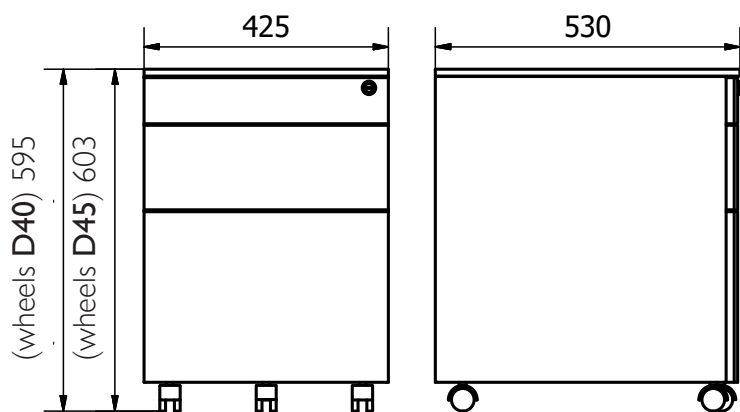
FEATURES

- Stationery tray | Internal dim. L352XP470XH25
Loading capacity 5kg
Partial extraction roller slides 4/5
- Drawers | Internal dim. L352XP470XH88
Loading capacity 15kg
Partial extraction roller slides 4/5
- Filing Cabinet | Internal dim. L330XP452XH248
Loading capacity 45kg
Full extension sliding guides
Folder-support framework
- Anti-overturning system
- Lock with jointed double key

PACKAGING

- Gross weight 23,3 kg
- Volume 0.133 mc
- Packaging in double layer box with handle and 8 paper angular supports
- Pallet 16pz 100x120 h230

PEDESTAL MOD. A300 (3 Drawers)

180 078 00	4 wheels d40 no brake
157 992 00	2 wheels d45 with brake 2 wheels d45 no brake

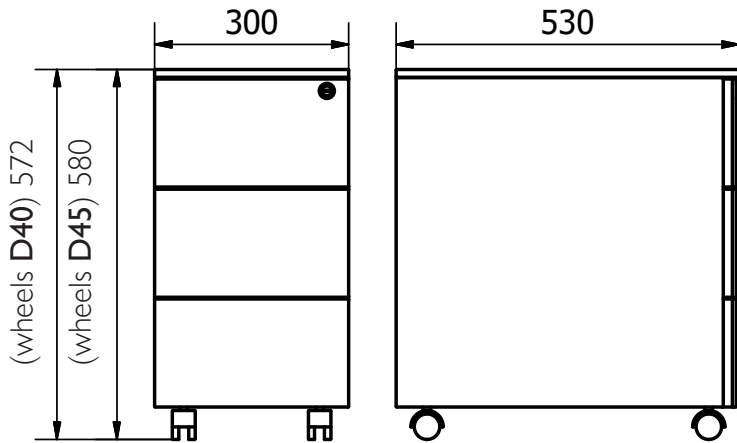
FEATURES

- Drawers | Internal dimensions L227XP470XH88
Loading capacity 15 kg
Partial extraction roller slides 4/5
- Anti-overturning system
- Lock with jointed double key

PACKAGING

- Gross weight 15 kg
- Volume 0.088 mc
- Packaging in double layer box with handle and 8 paper angular supports
- Pallet 24pz 100x120 h230

PEDESTAL MOD. C300 (1 Drawers / 1 Filing Cabinet)

155 657 00	4 wheels d40 no brake
157 993 00	2 wheels d45 with brake 2 wheels d45 no brake

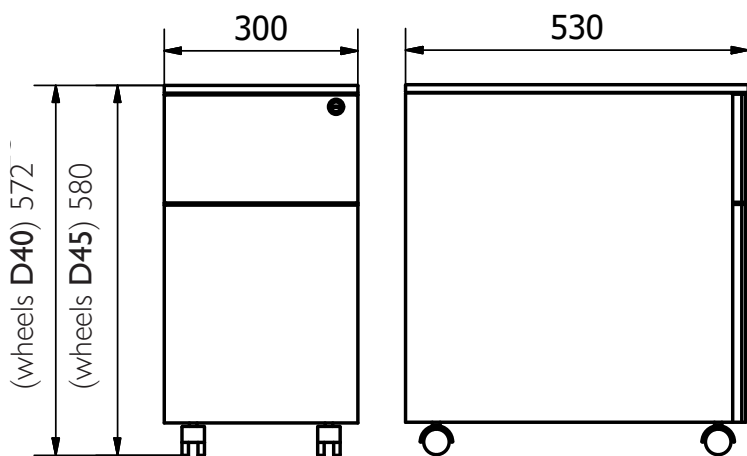
FEATURES

- Drawers | Internal dim. L227XP470XH88
Loading capacity 15 kg
Partial extraction roller slides 4/5
- Filing Cabinet | Internal dim. L227xp452xh270
Loading capacity 45 kg
Full extension sliding guide
Folder-support framework
- Anti-overturning system
- Lock with jointed double key

PACKAGING

- Gross weight 15 kg
- Volume 0.088 mc
- Packaging in double layer box with handle and 8 paper angular supports
- Pallet 24pz 100x120 h230

PEDESTAL MOD. PUF (2 Drawers)

156 061 67	2 wheels d45 with brake 2 wheels d45 no brake	with stationery tray
------------	--	-------------------------

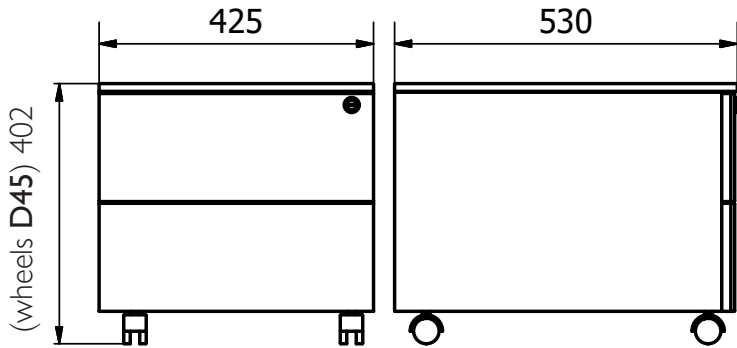
FEATURES

- Drawers | Internal dim. L352XP470XH88
Loading capacity 15 kg
Partial extraction roller slides 4/5
- Anti-overturning system
- Lock with jointed double key

PACKAGING

- Gross weight 14 kg
- Volume 0.087 mc
- Packaging in double layer box with handle and 8 paper angular supports
- Pallet 20pz 100x120 h230

PEDESTAL MOD. PUF WITH PILLOW (2 Drawers)

157 998 00	2 wheels d45 with brake 2 wheels d45 no brake	with stationery tray
------------	--	-------------------------

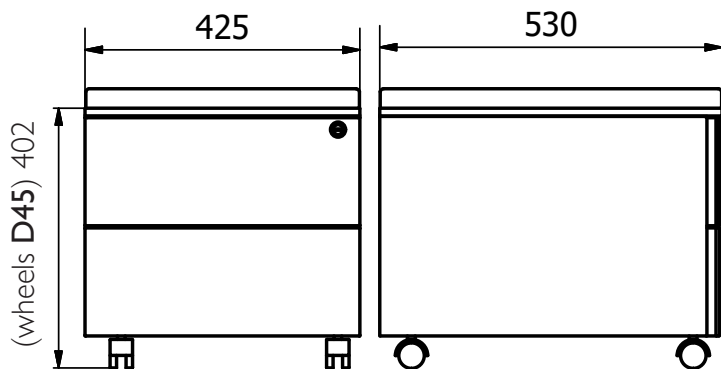
FEATURES

- Drawers | Internal dim. L352XP470XH88
Loading capacity 15 kg
Partial extraction roller slides 4/5
- Anti-overturning system
- Lock with jointed double key
- Pillow

PACKAGING

- Gross weight 14 kg
- Volume 0.087 mc
- Packaging in double layer box with handle and 8 paper angular supports
- Pallet 20pz 100x120 h230

3 DRAWER KIT

180 425 00	2 wheels d45 with brake 2 wheels d45 no brake
180 298 00	4 wheels d40

FEATURES

- Drawers | Internal dim. L352XP470XH88
- | Loading capacity 15 kg
- | Partial extraction roller slides 4/5
- Anti-overturning system
- Lock with jointed double key

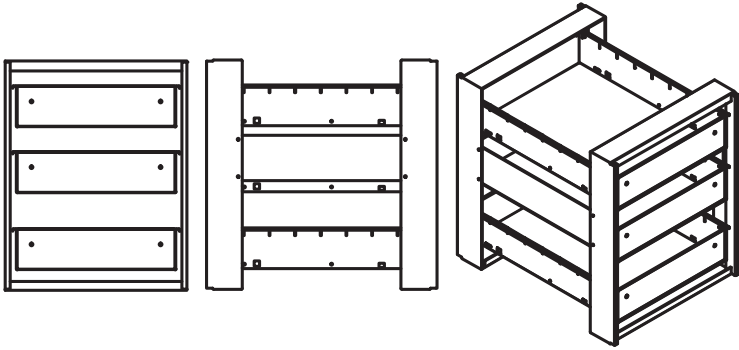

3 DRAWER KIT WITH FRONT AND WOODEN TOP

(all pedestals can be made with front and wooden top)

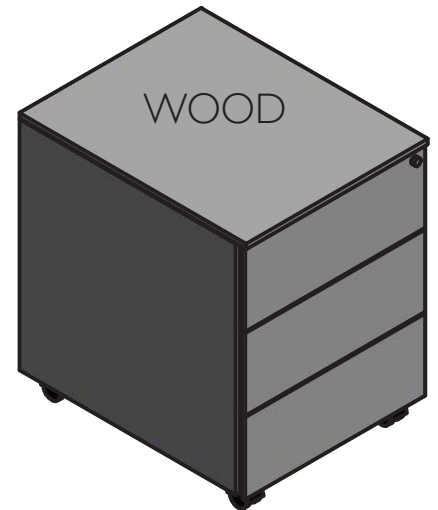
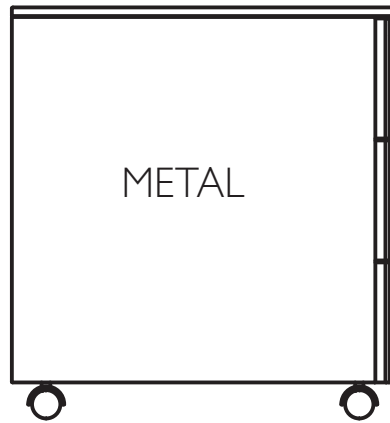
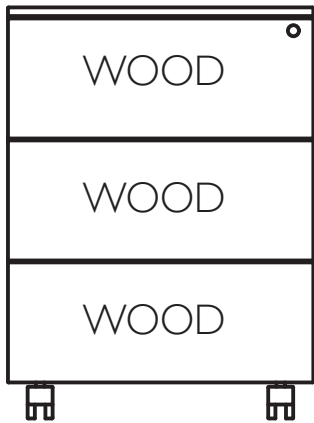

PLASTIC STATIONERY TRAY (36,5mm X 22mm)

(to be packaged with pedestal or individually)

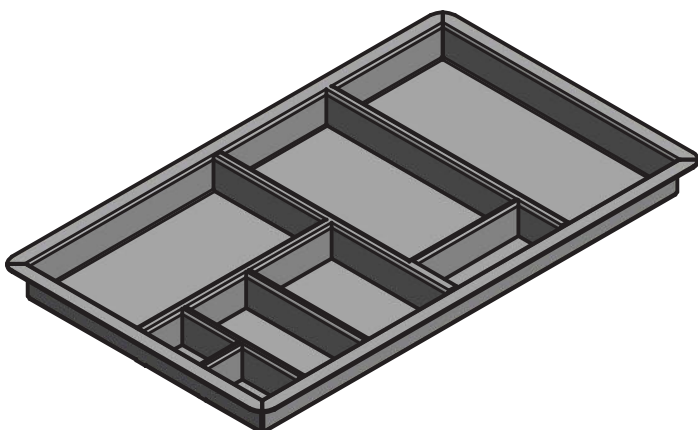

LOAD-BEARING PEDESTAL P600 MOD.B

(4 Drawers)

190 147 00	with stationery tray
190 148 00	without stationery tray

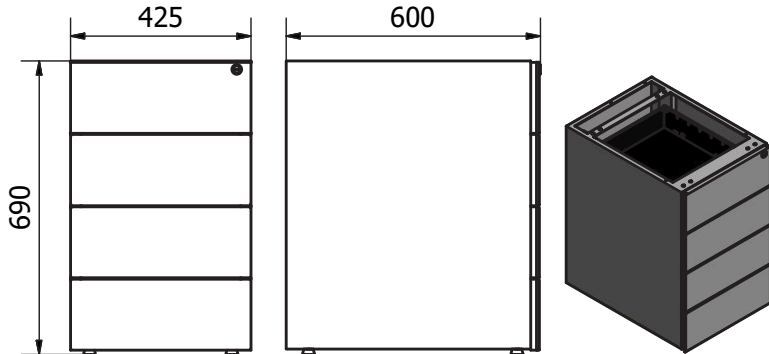
FEATURES

- Drawers | Internal dim. L352XP470XH88
Loading capacity 15kg
Partial extraction roller slides 4/5
- Anti-overturning system
- Lock with jointed double key
- Feet

PACKAGING

- Gross weight 32 kg
- Volume 0.19 mc
- Packaging in double layer box with handle and 8 paper angular supports
- Pallet 12pz 80x120 h230

LOAD-BEARING PEDESTAL P600 MOD.D

(2 Drawers / 1 Filing Cabinet)

190 149 00	with stationery tray
190 150 00	without stationery tray

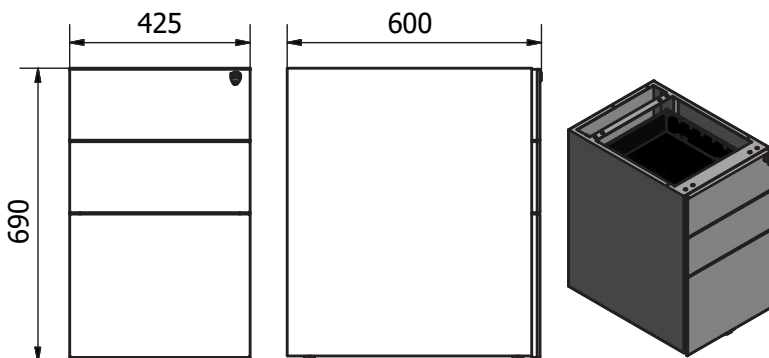
FEATURES

- Drawers | Internal dim. L352XP470XH88
Loading capacity 15kg
Partial extraction roller slides 4/5
- Filing Cabinet | Internal dim. L330XP452XH270
Loading capacity 45kg
Full extension sliding guide
Folder-support framework
- Wheel for Filing Cabinet
- Anti-overturning system
- Lock with jointed double key
- Feet

PACKAGING

- Gross weight 35 kg
- Volume 0.19 mc
- Packaging in double layer box with handle and 8 paper angular supports
- Pallet 12pz 80x120 h230

LOAD-BEARING PEDESTAL P600 MOD.M

(2 Filing Cabinet)

158 002 00	with stationery tray
158 003 00	without stationery tray

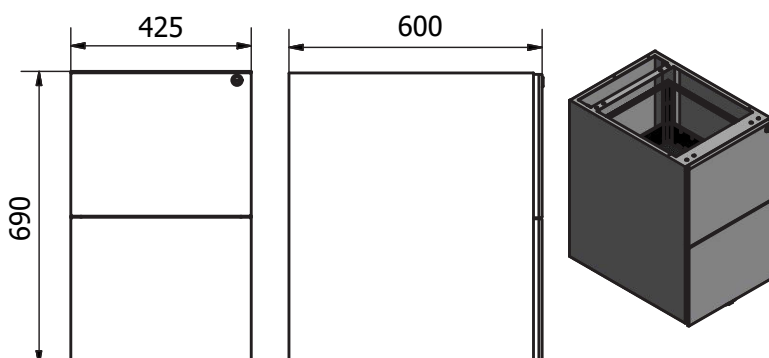
FEATURES

- Drawers | Internal dim. L330XP452XH270
Loading capacity 45kg
Full extension sliding guide
Folder-support framework
- Wheel for Filing Cabinet
- Anti-overturning system
- Lock with jointed double key
- Feet

PACKAGING

- Gross weight 38 kg
- Volume 0.19 mc
- Packaging in double layer box with handle and 8 paper angular supports
- Pallet 12pz 80x120 h230

LOAD-BEARING PEDESTAL P800 MOD.H

(4 Drawers)

190 211 00 with stationery tray

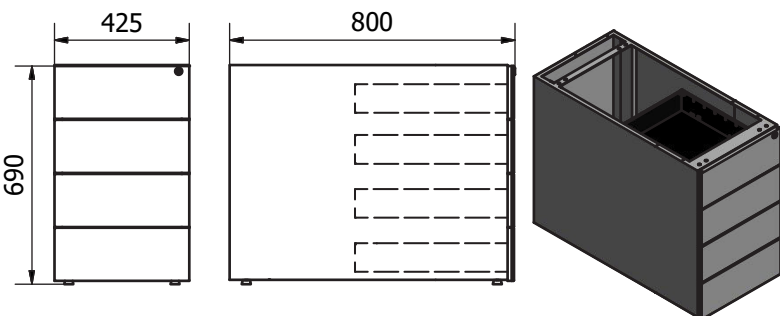
FEATURES

- Drawers | Internal dim. L352XP470XH88
Loading capacity 15kg
Partial extraction roller slides 4/5
- Anti-overturning system
- Lock with jointed double key
- Feet

PACKAGING

- Gross weight 34 kg
- Volume 0.24 mc
- Packaging in double layer box with handle and 8 paper angular supports
- Pallet 9pz 80x120 h230

LOAD-BEARING PEDESTAL P800 MOD.G

(2 Drawers / 1 Filing Cabinet)

157 999 00 with stationery tray

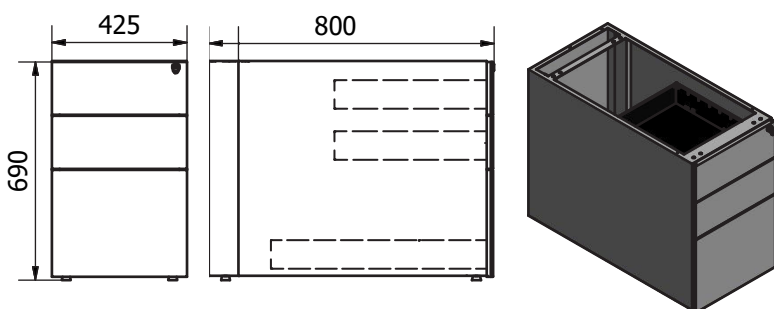
FEATURES

- Drawers | Internal dim. L352XP470XH88
Loading capacity 15kg
Partial extraction roller slides 4/5
- Filing Cabinet | Internal dim. L330XP652XH270
Loading capacity 45kg
Full extension sliding guide
Folder-support framework
- Wheel for Filing Cabinet
- Anti-overturning system
- Lock with jointed double key
- Feet

PACKAGING

- Gross weight 39 kg
- Volume 0.24 mc
- Packaging in double layer box with handle and 8 paper angular supports
- Pallet 9pz 80x120 h230

LOAD-BEARING PEDESTAL P800 MOD.N

(2 Filing Cabinet)

158 001 00 with stationery tray

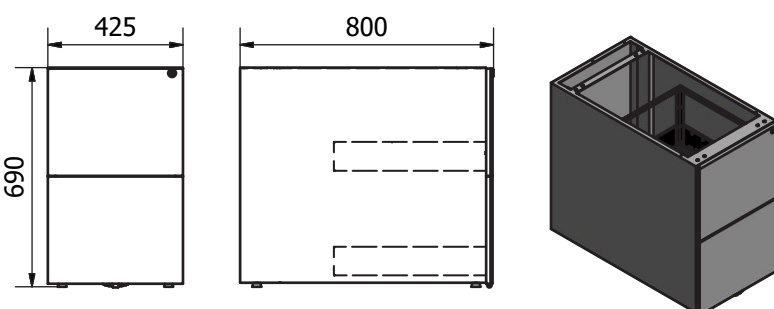
FEATURES

- Filing Cabinet | Internal dim. L330XP452XH270
Loading capacity 45kg
Full extension sliding guide
Folder-support framework
- Wheel for Filing Cabinet
- Anti-overturning system
- Lock with jointed double key
- Feet

PACKAGING

- Gross weight 40 kg
- Volume 0.24 mc
- Packaging in double layer box with handle and 8 paper angular supports
- Pallet 9pz 80x120 h230